

## POWER MANAGEMENT

### Low Power, 5V $\mu$ P Reset

- Active LOW, Open-Drain Output
- 350ms Reset Period

The IMP1233D supply voltage monitor is an improved, low-power replacement for the Dallas Semiconductor DS1233D. Maximum supply current over temperature is a low 20 $\mu$ A, representing over 60 percent lower power as compared to the DS1233D.

The IMP1233D issues an active LOW reset signal whenever the monitored supply is out-of-tolerance. A precision reference and comparator circuit monitor power supply ( $V_{CC}$ ) level. Tolerance level options are 5-, 10- and 15-percent. When an out-of-tolerance condition is detected, an internal power-fail signal is generated which forces an active LOW reset signal. After  $V_{CC}$  returns to an in-tolerance condition, the reset signal remains active for 350ms to allow the power supply and system microprocessor to stabilize.

The IMP1233D is designed with an open-drain output stage and operates over the extended industrial temperature range. Devices are available in compact surface mount SOT-223 packages and 3-lead TO-92 packages.

Other low power products in this family include the IMP1810/11/12/15/16/17 and IMP1233M.

### Key Features

- ◆ Improved Dallas DS1233D replacement
  - Over 60% lower maximum supply current
- ◆ Low Supply Current
  - 20 $\mu$ A maximum (5.5V)
  - 15 $\mu$ A maximum (3.6V)
- ◆ Automatically restarts a microprocessor after power failure
- ◆ 350ms reset delay after  $V_{CC}$  returns to an in-tolerance condition
- ◆ Active LOW power-up reset, 5k $\Omega$  internal pull-up
- ◆ Precision temperature-compensated voltage reference and comparator
- ◆ Eliminates external components
- ◆ Motorola 68xxx and HC16 compatible
- ◆ Low-cost TO-92 package
- ◆ Compact surface mount SOT-223 package
- ◆ Operating temperature -40 $^{\circ}$ C to +85 $^{\circ}$ C

### Family Selection Guide

Part	RESET Voltage (V)	RESET Time (ms)	Output Stage	RESET Polarity
IMP1810	4.620, 4.370, 4.120	150	Push-Pull	LOW
IMP1811	4.620, 4.350, 4.130	150	Open-Drain	LOW
IMP1812	4.620, 4.350, 4.130	150	Push-Pull	HIGH
IMP1815	3.060, 2.880, 2.550	150	Push-Pull	LOW
IMP1816	3.060, 2.880, 2.550	150	Open-Drain	LOW
IMP1817	3.060, 2.880, 2.550	150	Push-Pull	HIGH
IMP1233D	4.625, 4.375, 4.125	350	Open-Drain	LOW
IMP1233M	4.625, 4.375, 2.720	350	Open-Drain	LOW

### Applications

- ◆ Set-top boxes
- ◆ Cellular phones
- ◆ PDAs
- ◆ Energy management systems
- ◆ Embedded control systems
- ◆ Printers
- ◆ Single board computers

### Block Diagram

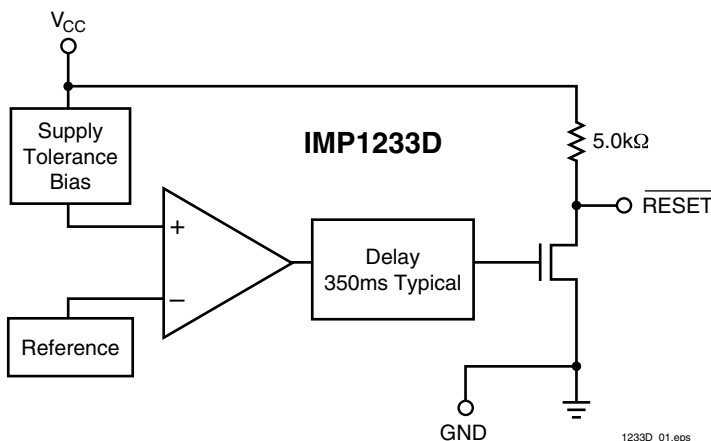

### Typical Application

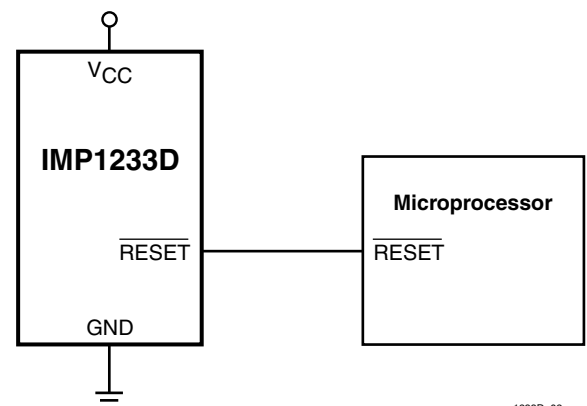

## Pin Configuration

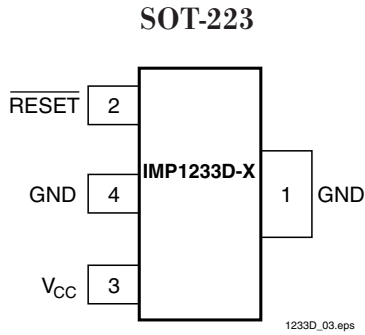

**TO-92\***

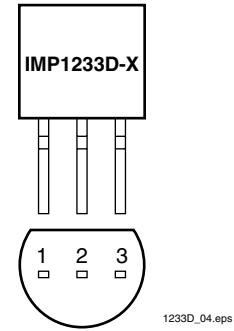

## Pin Descriptions

Pin Numbers		Name	Function
SOT-223	TO-92		
1	1	GND	Ground
2	2	$\overline{\text{RESET}}$	Active LOW reset output
3	3	V <sub>CC</sub>	Power supply input
4	—	GND	Ground (SOT-223 Only)

## Package Marking Code

Package Letter Code			Part Type	Package Letter Code	Reset Tolerance
A	B	C			
3	3	D	IMP1233D	D	
				A	5%
				B	10%
				C	15%

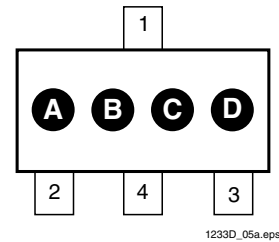

## Ordering Information

Device Summary									Package Marking			
Part Number	RESET Output Voltage (V)	RESET Tolerance (%)	RESET Time (ms)	Output Stage		TO-92* Package	SOT-223** Package	RESET Polarity	A	B	C	D
				*** Open-Drain	Push-Pull							A = 5% B = 10% C = 15%
IMP1233D-5	4.625	5	350	X		X		LOW				
IMP1233D-10	4.375	10	350	X		X		LOW				
IMP1233D-15	4.125	15	350	X		X		LOW				
IMP1233DZ-5	4.625	5	350	X			X	LOW	3	3	D	A
IMP1233DZ-10	4.375	10	350	X			X	LOW	3	3	D	B
IMP1233DZ-15	4.125	15	350	X			X	LOW	3	3	D	C

\* Add /S to Part Number for straight (unformed) leads. (ie. IMP1233D-xx/S)

\*\* Add /T to Part Number for Tape and Reel. (ie. IMP1233D-xx/T)

\*\*\* Internal 5kΩ resistor pull up.

## Absolute Maximum Ratings

Voltage on  $\overline{V_{CC}}$  ..... -0.5V to 7V  
 Voltage on  $\overline{RESET}$  ..... -0.5V to  $V_{CC} + 0.5V$   
 Operating Temperature Range ..... -40°C to 85°C

Soldering Temperature ..... 260°C for 10 seconds  
 Storage Temperature ..... -55°C to 125°C

*Voltages measured with respect to ground.  
 These are stress ratings only and functional operation is not implied.*

## Electrical Characteristics

Unless otherwise noted,  $V_{CC} = 1.2V$  to  $5.5V$  and specifications are over the operating temperature range of -40°C to +85°C.  
 All voltages are referenced to ground.

Parameter	Symbol	Conditions	Min	Typ	Max	Units
Supply Voltage	$V_{CC}$		1.2		5.5	V
Output Voltage	$V_{OH}$	$I_{OUT} < 500\mu A$	$V_{CC} - 0.5V$	$V_{CC} - 0.1V$		V
Output Current	$I_{OL}$	Output = 0.4V, $V_{CC} \geq 2.7V$	+8			mA
Operating Current	$I_{CC}$	$V_{CC} < 5.5V$ , $\overline{RESET}$ output open		8	20	$\mu A$
Operating Current	$I_{CC}$	$V_{CC} \leq 3.6V$ , $\overline{RESET}$ output open		6	15	$\mu A$
$V_{CC}$ Trip Point (IMP1233D-5)	$V_{CCTP}$		4.50	4.625	4.74	V
$V_{CC}$ Trip Point (IMP1233D-10)	$V_{CCTP}$		4.25	4.375	4.49	V
$V_{CC}$ Trip Point (IMP1233D-15)	$V_{CCTP}$		4.00	4.125	4.24	V
Internal Pull-Up Resistor	$R_P$		3.5	5.0	7.5	k $\Omega$
Output Capacitance	$C_{OUT}$				10	pF
RESET Active Time	$t_{RESET}$		250	350	450	ms
$V_{CC}$ Detect to $\overline{RESET}$ Low	$t_{RPD}$			2	5	$\mu s$
$V_{CC}$ Slew Rate ( $V_{HTL} - V_{LTL}$ )	$t_F$		300			$\mu s$
$V_{CC}$ Slew Rate ( $V_{LTL} - V_{HTL}$ )	$t_R$		0			ns
$V_{CC}$ Detect to $\overline{RESET}$ High	$t_{RPU}$	$t_R = 5\mu s$	250	350	450	ms

## Application Information

### Operation – Power Monitor

The IMP1233D detects out-of-tolerance power supply conditions. It resets a processor during power-up and issues a reset to the system processor when the monitored power supply voltage is below the reset threshold (power-down). When an out-of-tolerance  $V_{CC}$  voltage is detected, the  $\overline{\text{RESET}}$  signal is asserted. On power-up,  $\overline{\text{RESET}}$  is kept active (LOW) for approximately 350ms after the power supply voltage has reached the selected tolerance. This allows the power supply and microprocessor to stabilize before  $\overline{\text{RESET}}$  is released.

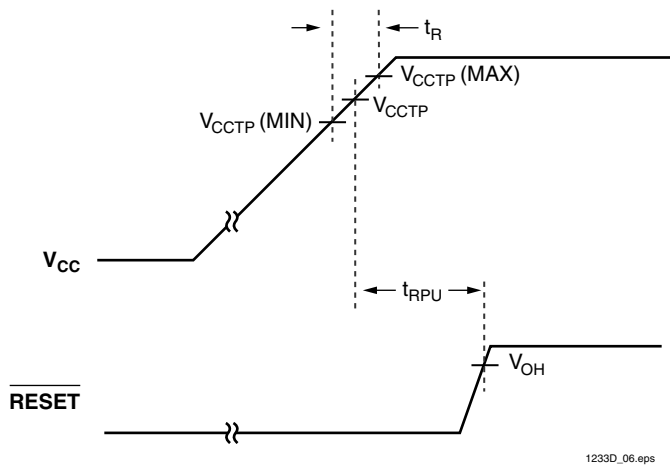

Figure 1. Timing Diagram: Power-Up

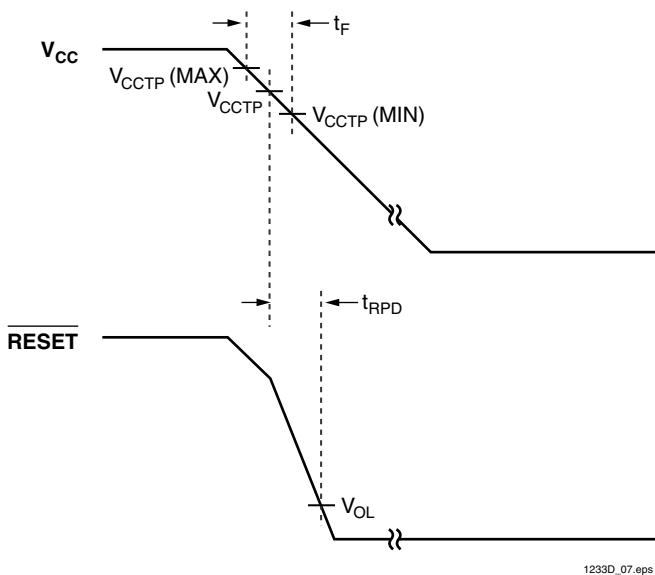
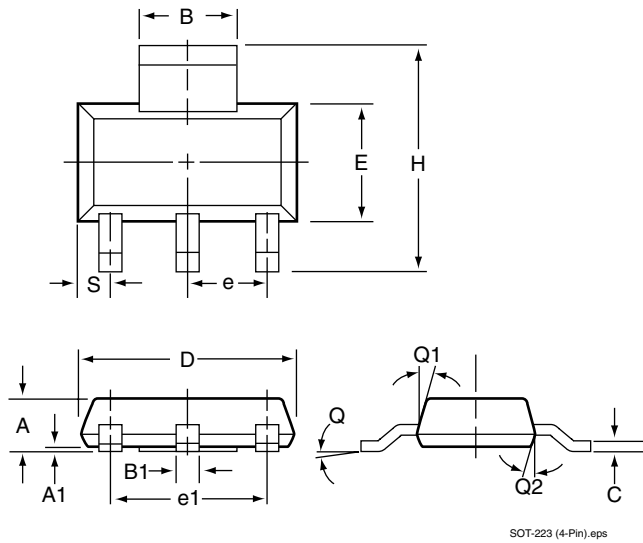

Figure 2. Timing Diagram: Power-Down

## Package Dimensions

### Plastic SOT-223 (4-Pin)



### TO-92 (3-Pin)

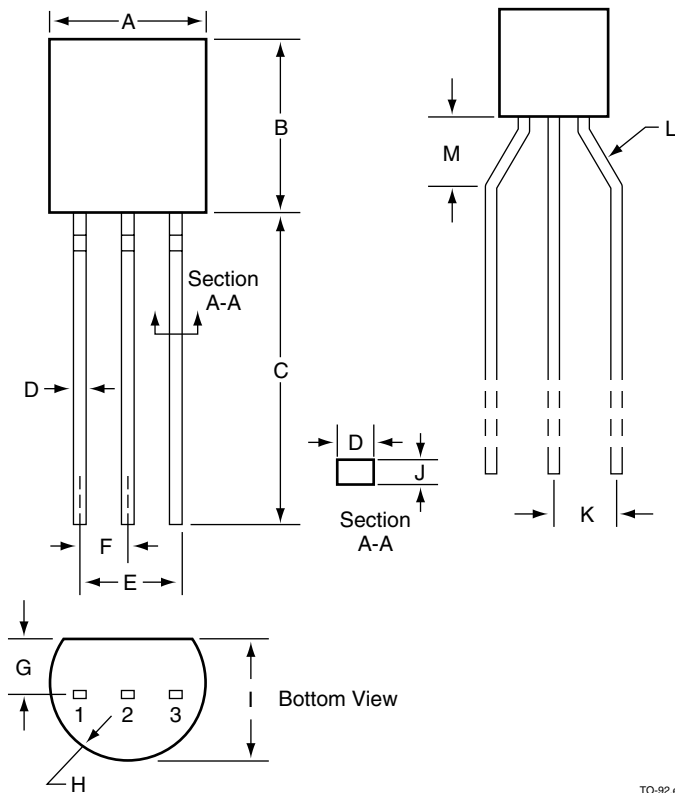

	Inches		Millimeters	
	Min	Max	Min	Max
<b>Plastic SOT-223* (4-Pin)</b>				
A	0.067	0.060	1.70	1.50
A1	0.004	0.0008	0.10	0.02
B	0.124	0.116	3.15	2.95
B1	0.033	0.026	0.85	0.65
C	0.014	0.010	0.35	0.25
D	0.264	0.248	6.70	6.30
e	0.0905 NOM		2.30 NOM	
e1	0.181 NOM		4.50 NOM	
E	0.146	0.130	3.70	3.30
h	0.287	0.264	7.30	6.70
S	0.041	0.033	1.05	0.85
t	0.051	0.043	1.30	1.10
Q	10° MAX		10° MAX	
Q1	16°	10°	16°	10°
Q2	16°	10°	16°	10°
<b>TO-92* (3-Pin)</b>				
A	0.175	0.195	4.45	4.95
B	0.170	0.192	4.32	4.96
C	0.500	0.610	12.70	15.49
D	0.016	0.022	0.406	0.559
E	0.095	0.105	2.41	2.67
F	0.045	0.60	1.14	1.52
G	0.45	0.060	1.14	1.52
H	0.085	0.095	2.16	2.41
I	0.130	0.155	3.30	3.94
J	0.014	0.020	0.35	0.51
K	0.093	0.115	2.36	2.92
L	45°	60°	45°	60°
M	0.118 Typical		3.00	

\* Formed leads are standard. Add /S to Part Number for straight leads.

\*\* Add /T to Part Number for Tape and Reel.

1233D04



IMP, Inc.  
Corporate Headquarters  
2830 N. First Street  
San Jose, CA 95134-2071  
Tel: 408-432-9100  
Tel: 800-438-3722  
Fax: 408-434-0335  
e-mail: [info@impinc.com](mailto:info@impinc.com)  
<http://www.impweb.com>

The IMP logo is a registered trademark of IMP, Inc.  
All other company and product names are trademarks of their respective owners.

© 1999 IMP, Inc.  
Printed in USA  
Publication #: 1012  
Revision: A  
Issue Date: 06/03/99  
Type: Preliminary